

Data Sheet | Item Number: 2059-301/998-403

SMD PCB terminal block; 0.5 mm²; Pin spacing 3 mm; 1-pole; PUSH WIRE®; in tape-and-reel packaging; 0,50 mm²; white

<https://www.wago.com/2059-301/998-403>



Color: ■ white

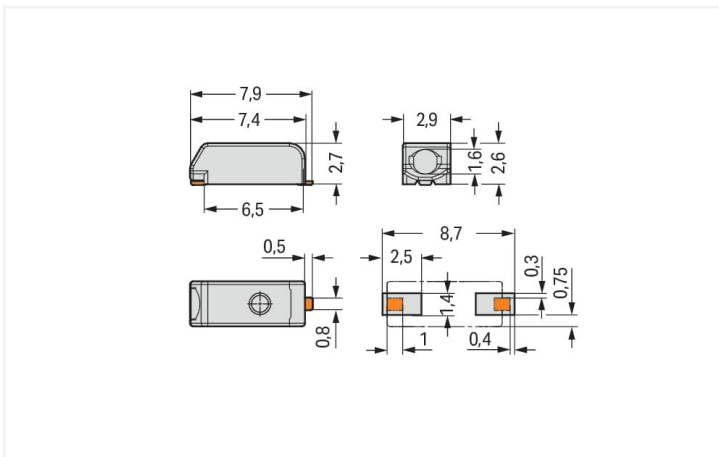

Dimensions in mm

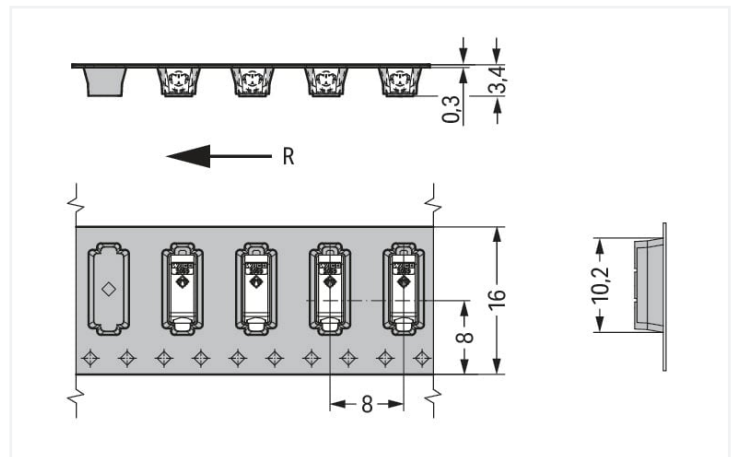

Dimensions in mm
R = feed direction

- SMD PCB terminal blocks with PUSH WIRE® connection technology
- Push-in termination of solid conductors
- Easy conductor removal via operating tool
- Just 2.7 mm tall
- Assemble terminal blocks without pole loss
- Available in tape-and-reel packaging for automated assembly

Notes

Note

Application notes:

Suitable for lead-free, reflow-soldering profiles per DIN EN 61760-1 and IEC 60068-2-58 up to max. 260°C peak temperature. Due to application-specific variables (component configuration and orientation, type of soldering machine, solder paste), trial runs are recommended to ensure product and process compatibility under actual manufacturing conditions.

Depending on reflow soldering temperatures and times, color deviations may occur. These deviations will have no impact on functionality.

Recommendation

Recommendation for stencil:

150 µm material thickness; Pattern layout identical to solder pad layout

Electrical data

Ratings per	IEC/EN 60664-1			Approvals per	UL 1977
	III	III	II		
Overvoltage category	III	III	II	Rated voltage	600 V
Pollution degree	3	2	2	Rated current	3 A
Nominal voltage	63 V	160 V	320 V		
Rated surge voltage	2.5 kV	2.5 kV	2.5 kV		
Rated current	3 A	3 A	3 A		

Connection data

Connection points	1	Connection 1	
Total number of potentials	1	Connection technology	PUSH WIRE®
Number of connection types	1	Actuation type	Operating tool
Number of levels	1	Solid conductor	0.14 ... 0.34 mm ² / 26 ... 22 AWG
		Note (conductor cross-section)	For conductors (26 AWG) that are not rigid enough, the clamping unit must be opened using an operating tool.
		Strip length	4 ... 5.5 mm / 0.16 ... 0.22 inches
		Conductor connection direction to PCB	0°
		Pole number	1

Connection 2

Solid conductor 2	0.5 mm ² / 20 AWG
Note (conductor cross-section) 2	No reconnection of smaller conductor cross-sections (0.5 mm ² /20 AWG)
Strip length 2	6 ... 7.5 mm / 0.24 ... 0.3 inches

Physical data

Pin spacing	3 mm / 0.118 inches
Width	2.9 mm / 0.114 inches
Height	2.7 mm / 0.106 inches
Depth	7.9 mm / 0.311 inches
Reel diameter of tape-and-reel packaging	330 mm
Tape width	16 mm

PCB contact

PCB contact	SMD
Solder pin arrangement	over the entire terminal strip (in-line)
Number of solder pins per potential	2

Material data

Note (material data)	Information on material specifications can be found here
Color	white
Material group	I
Insulation material	Polyphthalamide (PPA GF)
Flammability class per UL94	V0
Contact material	Copper alloy
Contact plating	Tin
Fire load	0.002 MJ
Weight	0.1 g

Environmental requirements

Limit temperature range	-60 ... +105 °C
-------------------------	-----------------

Commercial data

Product Group	33 (SMT Terminal)
eCl@ss 10.0	27-14-11-06
eCl@ss 9.0	27-14-11-06
ETIM 8.0	EC001284
ETIM 7.0	EC001284
PU (SPU)	31800 (2650) pcs
Packaging type	Box
Country of origin	CH
GTIN	4055143082679
Customs tariff number	85369010000

Environmental Product Compliance

RoHS Compliance Status	Compliant, No Exemption
------------------------	-------------------------

Approvals / Certificates

General approvals



Approval	Standard	Certificate Name
CCA DEKRA Certification B.V.	EN 60947	NTR NL-7819
CCA DEKRA Certification B.V.	EN 60947	71-111131
CCA DEKRA Certification B.V.	EN 60838	NTR NL-7720
KEMA/KEUR DEKRA Certification B.V.	EN 60838	71-106226
UL Underwriters Laboratories Inc.	UL 1977	E45171

1 Compatible Products

1.1 Optional Accessories

1.1.1 Board-to-board link

1.1.1.1 Board-to-board link



Item No.: 2059-901

Board-to-Board Link; Pin spacing 3 mm;
1-pole; Length: 15.3 mm; white



Item No.: 2059-901/018-000

Board-to-Board Link; Pin spacing 3 mm;
1-pole; Length: 17.5 mm; white



Item No.: 2059-901/021-000

Board-to-Board Link; Pin spacing 3 mm;
1-pole; Length: 20.5 mm; white

1.1.2 Tool

1.1.2.1 Operating tool



Item No.: 206-859

Operating tool; for 2059 Series; multicoloured



Item No.: 2059-189

Operating tool; made of insulating material; for 2059 Series

Installation Notes

Conductor termination



Insert solid conductors via push-in termination.

Conductor termination



Easy conductor removal, e.g., via operating tool (Item No. 206-859) or "twist & pull" (max. 10 x, no reconnection of smaller conductors possible)