

# Datasheet

CL4790

*Version 3.2*

---

## REVISION HISTORY

Version	Date	Notes	Contributors	Approver
1.0		Initial Release		Chris Downey
1.1		Changes and Revisions		Chris Downey
2.0	02 Aug 2013	Major changes and revisions; updated format and data		Chris Downey
3.0	18 Dec 2013	Separated Hardware Integration Guide (HIG) from User Guide information (created two separate documents). Add Related Documents section.		Sue White
3.1	28 May 2020	Fixed RS232-485 adapted diagram		Dave Drogowski
3.2	21 Oct 2022	Added FCC, ISED ID's (for revision 2.0 of product update). Added Antennas list (for revision 2.0 of product). Added Revision 2.0 Hardware section. Updated to Datasheet (previously Hardware Integration Guide) Updated to new template Added <a href="#">Ordering Information</a> .	Dave Drogowski Raj Khatri	Jonathan Kaye

## CONTENTS

1	CL4790 RF Transceiver .....	4
1.1	Overview .....	4
1.2	Features .....	4
1.3	Detailed Specifications .....	5
2	Status LEDs .....	7
2.1	CL4790 .....	7
3	Serial Interface .....	7
3.1	CL4790 Serial Interface .....	8
3.2	Hardware Flow Control .....	10
4	Hardware .....	12
4.1	Mechanical Drawing .....	12
4.2	Approved Antenna List .....	12
5	Revision 2.0 Hardware .....	13
6	Ordering Information .....	13
7	Related Documents and Files .....	14

# 1 CL4790 RF TRANSCEIVER

The CL4790 transceiver is a Frequency Hopping Spread Spectrum (FHSS) radio designed for license-free operation in the 900 MHz Industrial, Scientific, and Medical (ISM) unlicensed band. The radio sustains a standard asynchronous serial data stream between two or more radios. Housed in a compact and rugged die-cast enclosure, the radio is equipped to replace miles of serial cable with its wireless link. The radio features an RS232 or RS485 interface for integration into legacy data systems.

## 1.1 Overview

The CL4790 uses Frequency Hopping Spread Spectrum technology, where the units “hop” from frequency to frequency many times per second using a specific hop pattern applied to all the transceivers in the same network. A distinct hopping pattern is provided for each Channel Number, thereby allowing multiple networks to co-exist in the same area with limited interference.

CL4790 transceivers operate in a Masterless architecture. When a CL4790 has data to transmit, it will enter transmit mode and start transmitting a sync pulse intended for an individual radio or broadcast to all transceivers within the same network and range. Intended receivers synchronize to this sync pulse, a session begins, and data is transmitted. This instinctive dynamic peer-to-peer networking architecture enables several transceiver pairs to carry on simultaneous conversations on the same network.

CL4790s implement a proprietary communication protocol to provide secure data transmissions. Using FHSS technology ensures data reliability over long distances.

The CL4790 transceivers use the 900 MHz ISM license free frequency band, which requires no additional certifications when designing into a new or legacy data system.

Each unit is small and easily portable for use in mobile and temporary settings as well as fixed installations. The CL4790 configuration software enables custom configurations based on unique application requirements.

This document contains information about the hardware and software interface between a Laird Connectivity CL4790 transceiver and an OEM host. Information includes the theory of operation, specifications, serial interface definition, security information and mechanical drawings. The OEM is responsible for ensuring the final product meets all appropriate regulatory agency requirements listed herein before selling any product.

---

**Note:** CL4790 modules are referred to as the “radio” or “transceiver”. Individual naming differentiates product -specific features. The host (PC, Microcontroller or any connected device) is “OEM host.”

---

## 1.2 Features

- Masterless: True peer-to-peer; each module can communicate with any other module within its range and network
- API commands to control packet routing and acknowledgement on a packet-by-packet basis
- Durable industrial grade enclosure
- Transparent operation; supports any legacy system
- Transmits around corners, through walls
- Reliable communication with serial UART speeds up to 115.2 Kbps
- Point-to-Point and Point-to-Multipoint setups

## 1.3 Detailed Specifications

**Table 1: CL4790-1000 Specifications**

INTERFACE	
Serial Interface Connector	DB-9 Male (RS232), Terminal Block (RS485)
RF Connector	RPSMA Jack
Serial Interface Data Rate	Baud rates from 1200 bps to 115.2 Kbps
Power Consumption	400 mA @ 12 VDC
Channels	US/Canada: 32 channels Australia: 8 channels
Supported Network Topologies	Point-to-Point, Point-to-Multipoint
Security	One byte System ID. 56-bit DES encryption key.
Interface Buffer Size	Input/Output: 256 bytes each

OPERATIONAL			
Frequency Band	902 – 928 MHz (US/Canada) 915 – 928 MHz (US/Canada, Australia)		
RF Data Rate	76.8 Kbps fixed		
Host Data Throughput	20.5 Kbps maximum		
RF Technology	Frequency Hopping Spread Spectrum (FHSS)		
EEPROM write cycles	20000		
Hop Period	50 ms		
Output Power	<b>Conducted (no antenna)</b>	<b>EIRP (3dBi gain antenna)</b>	
	CL4790-1000	743 mW typical	1486 mW typical
Supply Voltage	CL4790-1000: 7-28VDC; 400 mA		
Receiver Sensitivity	-100dBm typical @ 76.8 kbps RF Data Rate		
Range, Line of Sight (based on 3dBi gain antenna)	Max. 1500 feet (450 m) indoors; Max. 20 miles (32 km) line-of-sight		

POWER SETTINGS (Input Voltage: 12 v DC)				
Transmit – Full Duty Cycle	Max Power Setting	Current (mA)	dBm	mW
	Low	157	10	10
	Quarter	225	23	200
	Half	280	26	400
	Full	365	28	743

**POWER SETTINGS (Input Voltage: 12 v DC)**

Receive – Transceiver in Idle	Max Power Setting	Current (mA)
	Low	50
	Quarter	50
	Half	50
	Full	50

**ENVIRONMENTAL**

Temperature (Operational)	-40° C to +80° C
Temperature (Storage)	-50° C to +85° C
Humidity (Non-Condensing)	10% to 90%

**PHYSICAL**

Dimensions	4.4 x 2.7 x 1.4 inches
Weight	6 oz. (170 g)

**CERTIFICATIONS**

FCC Part 15.247	CL4790-1000: SQG-CL4490 (for Revision 2.0 hardware) (See <a href="#">PCN 6E-2022</a> ) CL4790-1000: KQL-AC4490 (for pre-Revision 2.0 hardware)
Industry Canada (ISED)	CL4790-1000: 3174A-CL4490 (for Revision 2.0 hardware) (See <a href="#">PCN 6E-2022</a> ) CL4790-1000: 2268C44901000 (for pre-Revision 2.0 hardware)



**Caution!** ESD Sensitive Component. Use proper ESD precautions when handling this device to prevent permanent damage.

External ESD protection is required to protect this device from damage as required to pass IEC 61000-4-2 or ISO 10605 based on end system application.

## 2 STATUS LEDs

### 2.1 CL4790

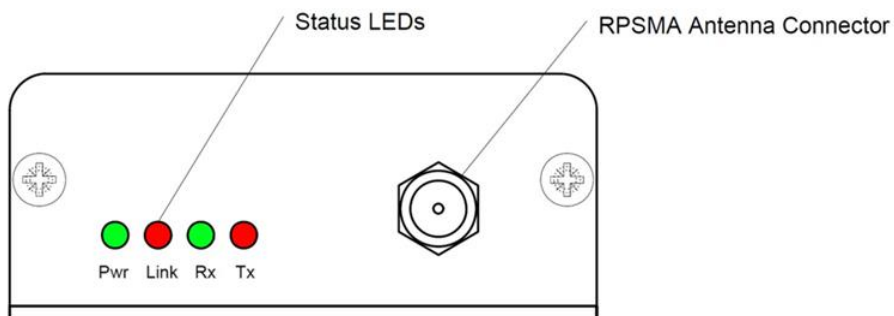

**Figure 1: CL4790 Status LEDs**

Table 2 describes each of the CL4790 Status LEDs.

**Table 2: CL4790 Status LEDs**

LED	Color	Description
Pwr	Green	On. Indicates the unit is powered up.
Link	Red	On. Indicates the CL4790 is In Session.
RXD	Green	When flashing, indicates the CL4790 is receiving data.
TXD	Red	When flashing, indicates the CL4790 is transmitting data.

## 3 SERIAL INTERFACE

- [CL4790 Serial Interface](#)
- [Hardware Flow Control](#)

The CL4790 supports the following protocols, which are separate products:

- [RS232](#)
- [RS485](#)

## 3.1 CL4790 Serial Interface

### 3.1.1 RS232

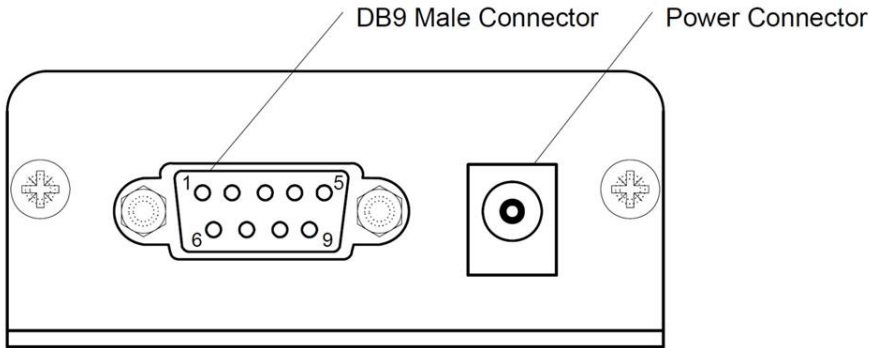
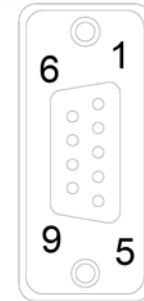

Figure 2: CL4790-RS232

RS232 is a single-ended data transmission protocol. The RS232 signals are represented by voltage levels with respect to a system common (power/logic ground). The “idle” state (MARK) has the signal level negative with respect to common, and the “active” state (SPACE) has the signal level positive with respect to common.

Table 3: CL4790 DB9 Male Connector Pinout (as defined at the CL4790)

DB9 Pin	Signal Name	Description	Direction
1	DCD	Data Carrier Detect	Out
2	TXD (RXD with respect to DTE)	Transmit Data	Data Out to Host
3	RXD (TXD with respect to DTE)	Receive Data	Data In to CL4790
4	DTR	Data Terminal Ready	In
5	GND	Ground	-
6	DSR	Data Set Ready	Out
7	RTS	Request to Send	In
8	CTS	Clear to Send	Out
9	RI	Ring Indicator	Out



### 3.1.2 Interfacing to Other RS232 Equipment

The CL4790 is a DCE (Data Communications Equipment) device. Typically, devices like PCs are considered DTE (Data Terminal Equipment) devices while peripheral devices are classified as DCE. A DCE device can interface to a DTE device using a straight-through serial cable. When interfacing two DCE (or two DTE) devices together, a null modem cable (or crossover cable) is required to swap the pins and convert the signals accordingly.



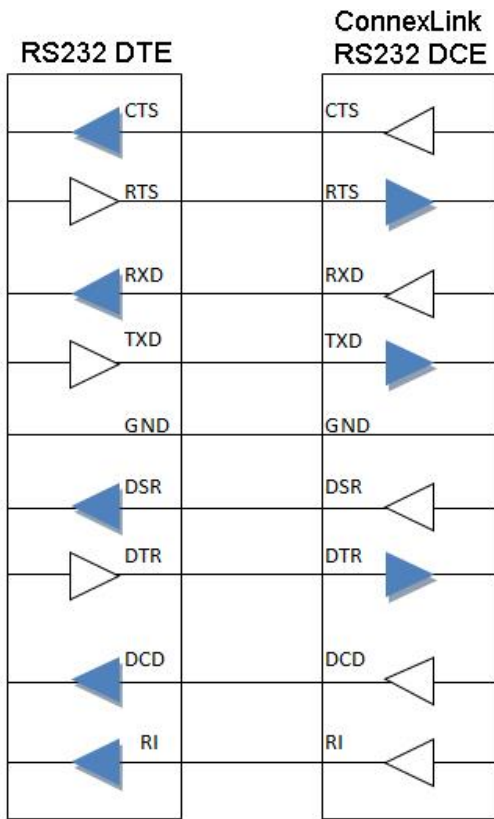

**Figure 3: DTE to DCE interface (all signals with respect to DTE)**

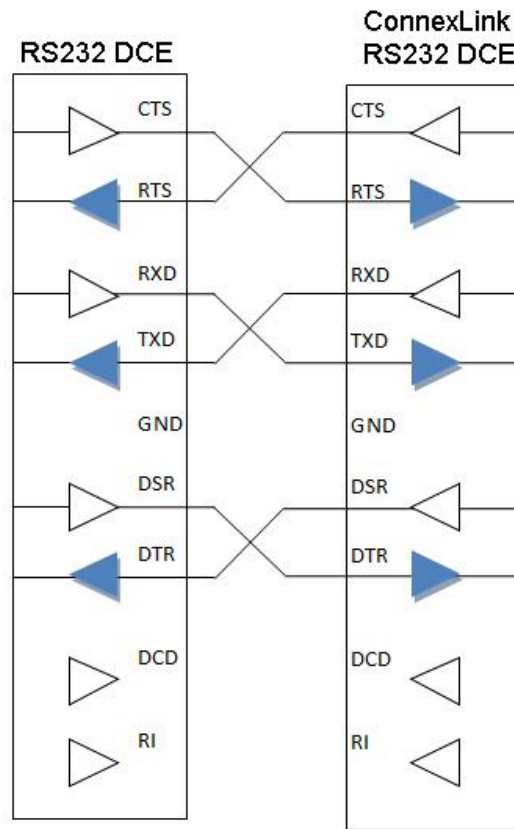

**Figure 4: DCE to DCE interface (all signals with respect to DTE)**

**Note:** When using a pair of CL4790s to connect a PC to a peripheral unit, if you previously used a straight-through serial cable to connect your PC to your peripheral device, you'll need to use a straight-through serial cable between the PC and the CL4790 and a null modem adapter, or cross-over cable, between the other CL4790 and the peripheral device.

### 3.1.3 RS485

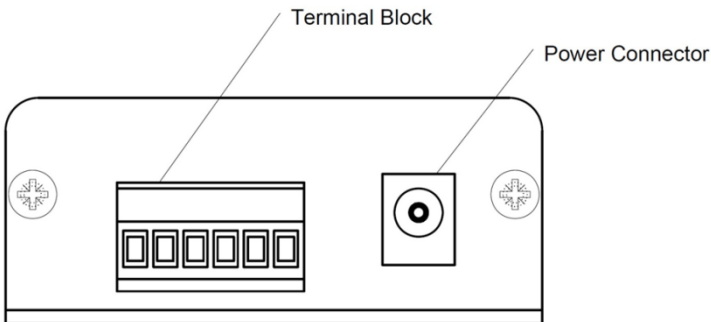

**Figure 5: CL4790-RS485**

The RS485 interface uses a Differential Data Transmission that can help nullify the effects of ground shifts and induced noise signals that can appear as common mode voltages on a network.

The CL4790 uses a RS485 (2-wire Half Duplex) multi-drop interface. Typically, a RS485 bus consists of a master and several slaves. The nodes have unique addresses and can send addressed packets to specific nodes. Because the bus is half duplex, no two nodes should try to talk at the same time. The CL4790 does not have a RS485 address; therefore it transmits all RS485 traffic over the RF. Conversely, as soon as the CL4790 receives a packet over the RF, it transmits the packet over the RS485 bus.

**Table 4: CL4790 Terminal Block Pinout**

Terminal Block Pin	Signal Name	Description
1	VCC	6-18V (1.3A required)
2	485 -	485A-
3	N/C	No Connect
4	N/C	No Connect
5	485 +	485B+
6	GND	Ground

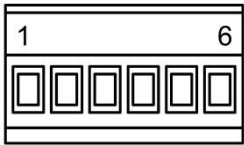

**Note:** When using RS485 (2-wire Half Duplex), a RS485 to RS232 converter is required to configure the unit. Laird Connectivity recommends a B&B Electronics 485SD9TB converter to translate RS485 to RS232.

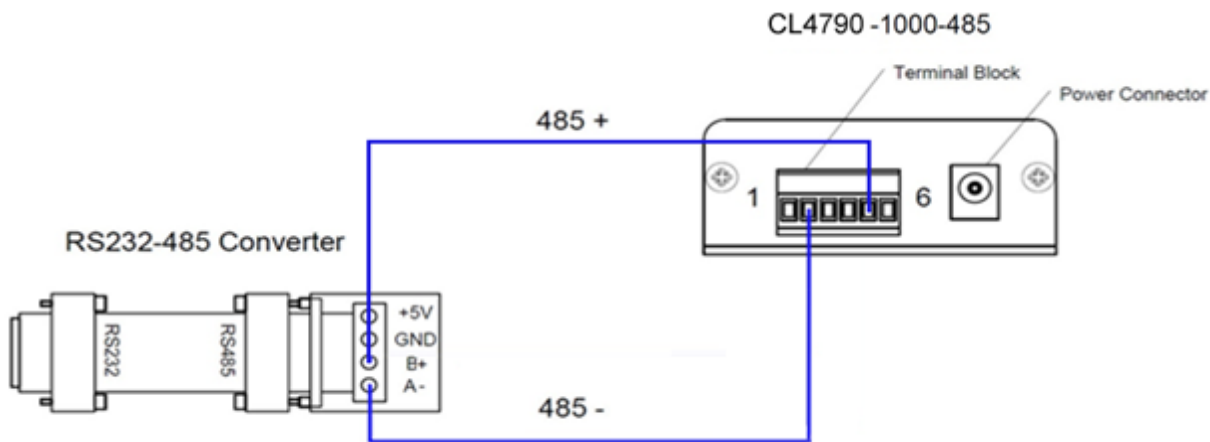

**Figure 6: RS232-485 Converter**

**Note:** Many simple 2- or 4-wire converters do not provide hardware flow control capabilities and therefore require you to disable handshaking by setting Handshaking to None in the Laird Connectivity Configuration Utility. Check with your converter manufacturer for any specific requirements.

## 3.2 Hardware Flow Control

Flow control refers to the control of data flow between the host and the CL4790. It is the means of handling data in the transmit/receive buffer of the CL4790 interface and it determines the throttling of data flow between the host and the CL4790. Often in serial communication, one device is capable of sending data much faster than the other can receive. Flow control allows the slower device to tell the faster device to pause and resume data transmission. Because flow control signals CTS and RTS are used by the CL4790 and its host **locally** (rather than over the air), one CL4790 cannot tell the other CL4790 to slow down or speed up.

The CL4790 controls the Clear to Send (CTS) output to the OEM host. The state of the CTS pin is based on the amount of data in the interface buffer. If the buffer is below the maximum limit, the transceiver holds CTS logic Low to signal to the OEM

host that data can be accepted over the serial interface safely. If the buffer is full, then CTS transitions logic High to signal to the OEM host that additional data sent over the serial bus has the potential to be lost due to buffer overflow.

Ready to Send (RTS) is an input to the CL4790 from the OEM host. When the *RTS Enable* option is selected in the software configuration of the CL4790, the transceiver checks the status of RTS before attempting to send received RF data to the OEM host. If RTS is logic Low, the transceiver sends data to the OEM host. If RTS is logic High, it does not send data to the host.

---

**Note:** CTS is always enabled by default. RS485 Interface does not support Hardware flow control.  
RTS is high by default on the CL4790. If RTS Enable is enabled, the CL4790 does not transmit data out the serial interface unless the RTS line is driven low by the OEM host.

---

---

**Tip :** Can I implement a design using just Txd, Rxd and Gnd (Three-wire Interface)?

Yes. However, Laird Connectivity strongly recommends that your hardware monitor the CTS pin of the radio. CTS transitions logic High by the radio when its interface buffer is getting full. Your hardware should stop sending data over the serial interface at this point to avoid a buffer overrun (and subsequent loss of data).

You can perform a successful design without monitoring CTS. However, you need to take into account the amount of latency the radio adds to the system, any additional latency caused by Transmit Retries or Broadcast Attempts, how often you send data, non-delivery network timeouts, and interface data rate. Polled type networks, where a centralized host requests data from the surrounding hosts and the surrounding hosts respond, are good candidates for avoiding the use of CTS. This is because no one transceiver can monopolize the RF link. Asynchronous type networks, where any radio can send to another radio at any point in time, are much more difficult to implement without the use of CTS.

---



**Note:** You may use different antenna manufacturers as long as the antenna is of like type and equal or lesser gain to one of the antennas listed in the table above.

**Table 6: CL4790 approved antennas (for Revision 2.0 hardware)**

Laird Part Number	Manufacturer Part Number	Manufacturer	Type	Gain (dBI)	Frequency Band (MHz)
0600-00024	S467AH-915S	Nearson	1/2 Wave Dipole	2	902-928
0600-00030	S331AH-915	Nearson	1/4 Wave Dipole	2	902-928

**Note:** You may use different antenna manufacturers as long as the antenna is of like type and equal or lesser gain to one of the antennas listed in the table above.

## 5 REVISION 2.0 HARDWARE

The Qorvo RF power amplifier (RF2173) used on old pre-revision 2.0 hardware is now EoL (End of Life) and the redesigned Revision 2.0 hardware uses a new Qorvo RF power amplifier (RF6886).

Additionally, revision 2.0 hardware has the following changes to help ease sourcing issues:

- Changed RF filters (LPF ceramic and BPF SAW) but with similar specifications.
- 14.7456MHz crystal changed and body size reduction, but with similar specifications.
- Passive component body size reduction
- and therefore, PCB layout changed.

Revision 2.0 hardware is form, fit, function equivalent to older pre-revision 2.0 hardware.

CL4790-1000 revision 2.0 hardware can operate from 7V to 28V (instead of 7V to 18V on older hardware).

CL4490-1000 revision 2.0 hardware can operate from 7V to 28V (instead of 7V to 18V on older hardware).

CL4490-1000-PRO revision 2.0 hardware still operates from 7V to 28V (same as on older hardware).

See [PCN 6E-2022](#).

## 6 ORDERING INFORMATION

Part (Product Name)	Type	Interface	Output Power
CL4790-1000-232	Unit	RS232	1W
CL4790-1000-232-SP	Starter Pack	RS232	1W
CL4790-1000-485	Unit	RS485	1W
CL4790-1000-485-SP	Starter Pack	RS485	1W

## 7 RELATED DOCUMENTS AND FILES

The following additional CL4790 technical documents are also available from the [CL4790 product page](#):

- Product Brief
- CL4790 User Guide

The following downloads are also available:

- Configuration Utility
- USB Drivers